

SPECIFICATIONS

CONTACT CARRIER MATERIAL	NYLON or PBT
CONTACT MATERIAL/PLATING	BRASS/GOLD
CONNECTOR HOUSING MATERIAL/PLATING	BRASS/NICKEL
O-RING/GASKET MATERIAL	RUBBER (NITRILE or FPM)
RATED CURRENT [A]	3.0 A
RATED VOLTAGE [V]	150 V
NUMBER OF CONDUCTORS [AWG]	16x18 AWG
PROTECTION CLASS	IEC IP65

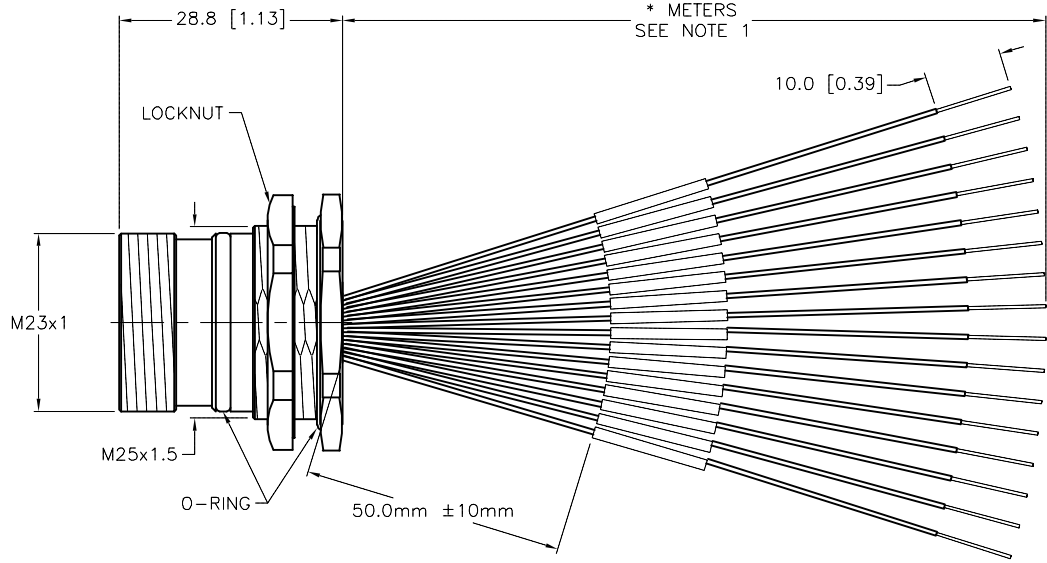
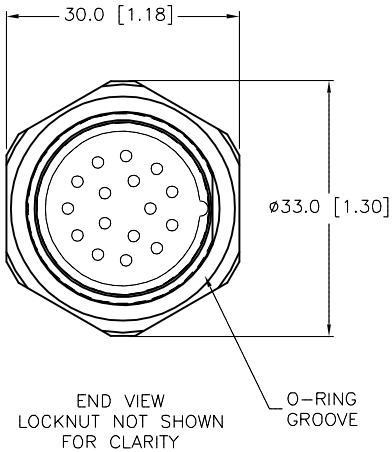

CABLE LENGTH	TOLERANCE*
ALL LENGTHS	+ 4% (OR 50mm) OF LENGTH - 0% (OR 0mm) OF LENGTH WHICHEVER IS GREATER
STRIP LENGTH	TOLERANCE*
0-7mm	±0.5mm
8-29mm	±1.0mm
30-49mm	±2.0mm
50-69mm	±3.0mm
70-100mm	±4.0mm
OVER 100mm	±5.0mm

*UNLESS OTHERWISE SPECIFIED

- NOTES:
- "*" INDICATES LEAD LENGTH IN METERS. CONTACT TURCK TO ORDER SPECIFIC LENGTHS.
 - MAXIMUM WALL THICKNESS 6.5 [.256].
 - "/S613" DESIGNATES 18 AWG CONDUCTORS.
 - "/CS14053" DESIGNATES CUSTOM PINOUT. WRAP LABELS ON ALL SAME COLORED CONDUCTORS. WRAP LABELS NUMBERED WITH CORRESPONDING WIRE IDENTIFICATION NUMBERS. ("1" EQUALS "BLUE #1").

SOURCE DRAWING - FOR REFERENCE ONLY

RELATED DOCUMENTS 1. 2. 3. 4.	3RD ANGLE PROJECTION 	THIS DRAWING IS CONFIDENTIAL AND THE PROPERTY OF TURCK INC. USE OF THIS DOCUMENT WITHOUT WRITTEN PERMISSION IS PROHIBITED.		3000 CAMPUS DRIVE MINNEAPOLIS, MN 55441 1-800-544-7769 (763) 553-7300 (763) 553-0708 fax www.turck.us	
	MATERIAL SEE SPECIFICATIONS	DRFT KMY APVD T.K.	DATE 05/28/13 SCALE 1=1.0	DESCRIPTION CKFD 16-16-*/S613/CS14053	
FINISH SEE SPECIFICATIONS	ALL DIMENSIONS DISPLAYED ON THIS DRAWING ARE FOR REFERENCE ONLY	UNIT OF MEASUREMENT MILLIMETER [INCH]		IDENTIFICATION NO.	REV B
B UPDATE GASKET MATERIAL ER 11/20/19 75415		DO NOT SCALE THIS DRAWING		FILE: 777031840	SHEET 1 OF 1
REV DESCRIPTION BY DATE ECO NO.					